



CobraRTP

MotronicRT

User Manual

Rev. 1.4



CONNECTION TO ECU

MotronicRT is connected using the Socket-extension cable from the kit:

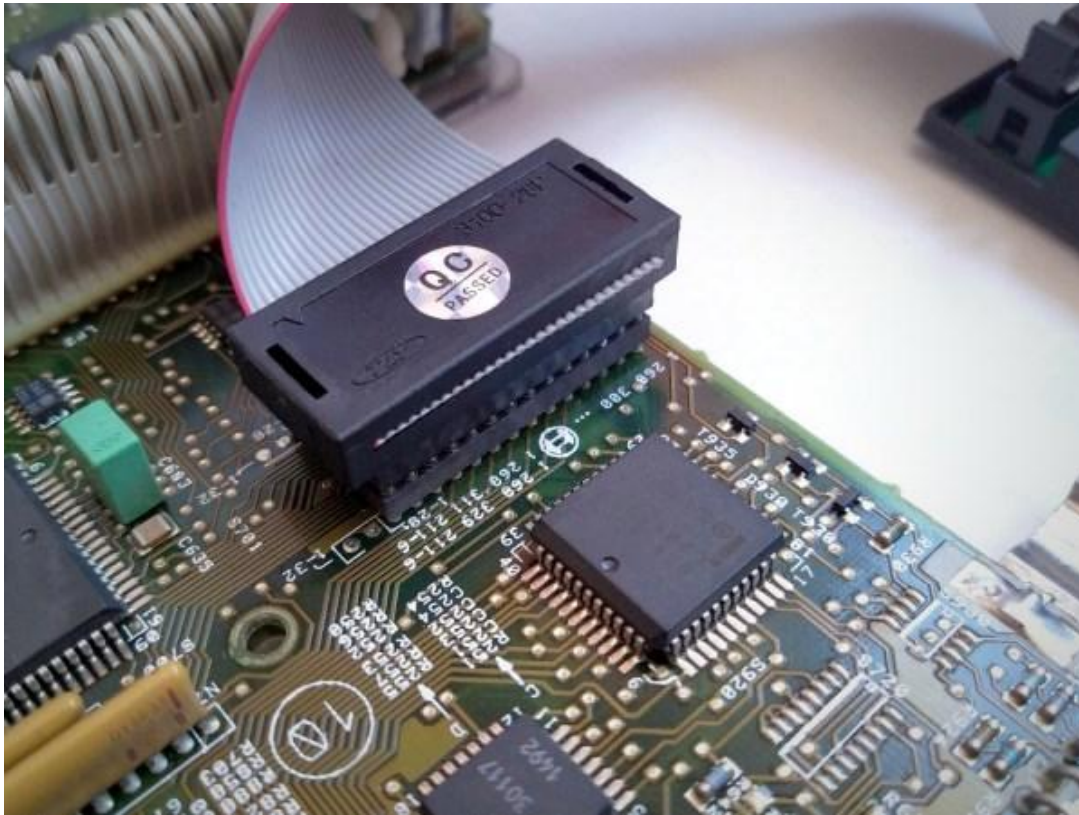

Example for Bosch DME 402, 403, 405

Correct connection must be observed as shown in the figures below:

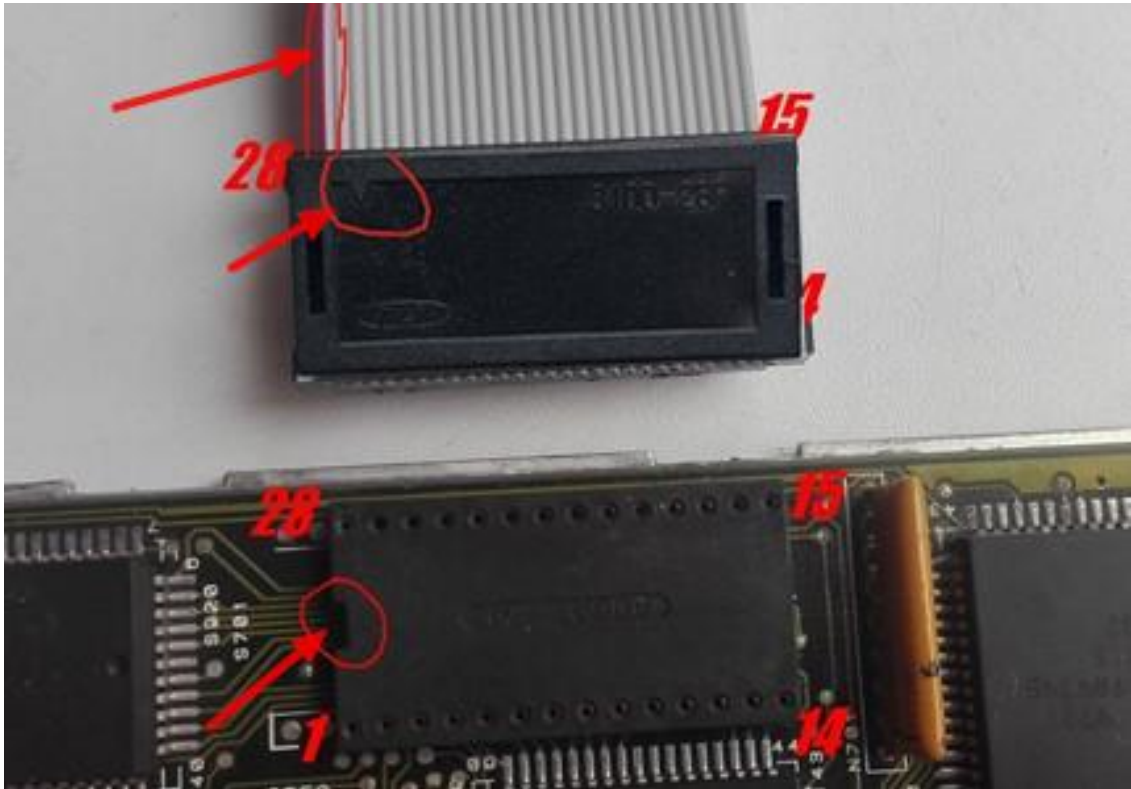

It is necessary to navigate the red or white strip on the cable and the cutout on the socket, which should be on one side!

If connected correctly, after on ignition, the “Status” LED on the MotronicRT board should light up.

PREPARATION OF THE ECU WITH CHIPS 28F512 (32 pin)

Since the package of this type of memory usually has 32 pins, for compatibility, you need to connect the emulator connector with an offset:

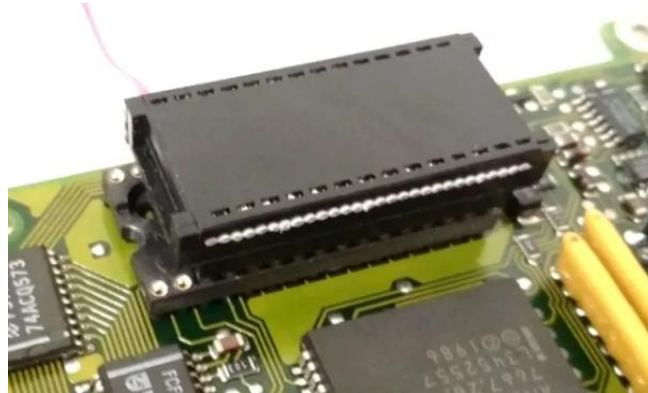

Such ECUs include, for example, Siemens MS40.1, IAW 1AP.40.

It is also necessary to connect pins 30 and 32 (NC and Vcc) to ensure reliable power supply to the emulator:



After all the manipulations, with the correct connection, after turning on the ECU (ignition) on the MotronicRT board, the “Status” indicator should light up.

This jumper can be left permanently even if you plan to install a chip.

CONNECT TO PC

USB-Version

MotronicRT (USB) is connected to a PC using a USB type-B cable.

MotronicRT can only be connected to a PC, i.e. There is no need to install (connect) the emulator in the ECU.

Connection setup

After connecting, you should have a new device in the Device manager. After that, you need to install the USB driver.

Installing the USB driver

For revisions R5 and later, the **driver is not required for Windows 10/11**. If you use **Windows XP, Vista, 7, 8.x** driver installation is required.

The driver can also be downloaded from our website: <https://cobrartp.com/en/downloads>.

To install the driver, use the installer for the appropriate version of Windows:

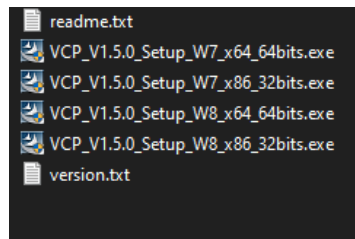

After the driver installation is successfully completed, a virtual COM port will appear in the device manager, if there is a connected emulator:

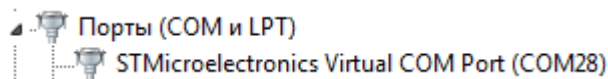

View of the device in the device manager when the driver is successfully installed

Installing the USB driver for revisions R1.3-R4.3 (Only old MotronicRT versions)

Drivers can be downloaded on our website: <https://cobrartp.com/en/downloads>, by selecting an item for the appropriate version of Windows.

After downloading the driver archive, you must also select the appropriate installer, depending on the bit depth of your operating system x86 (x32) or x64. Drivers tested on Windows XP, Windows 7, Windows 10. Official website of the driver provider: <https://www.silabs.com/products/development-tools/software/usb-to-uart-bridge-vcp-drivers>.

Customization	23.06.2018 0:27	Папка с файлами	
x64	23.06.2018 0:28	Папка с файлами	
x86	23.06.2018 0:28	Папка с файлами	
CP210xVCPInstaller_x64.exe	20.11.2015 9:58	Приложение	1 031 КБ
CP210xVCPInstaller_x86.exe	20.11.2015 9:58	Приложение	909 КБ
cp2102.rar	30.01.2018 16:43	WinRAR archive	3 562 КБ
dpinst.xml	20.11.2015 9:55	Документ XML	12 КБ
SLAB_License_Agreement_VCP_Windows.	20.11.2015 9:55	Текстовый докум	9 КБ
slabvcp.cat	25.11.2015 18:03	Каталог безопасн...	11 КБ
slabvcp.inf	25.11.2015 17:56	Сведения для уст...	12 КБ

Type of driver distribution.

The installation process is standard.

If there is no installer in the folder (Windows 10/11), the driver must be installed through the Device Manager: By device (MotronicRT), right-click - Properties - Driver - Update driver. Next, select the folder with the downloaded drivers.

After the driver installation is successfully completed, a virtual COM port should appear in the **device manager**, if there is a connected emulator:

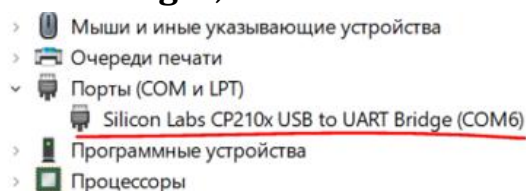

View of the device in the device manager upon successful driver installation.

After installing the drivers, you can use the emulator with the configuration software, and also check it in the **CobraRTP Utility**.

Note: COM port number may be different from the one shown above.

Bluetooth connection (if BT module installed)

To do this, your PC must have a built-in Bluetooth or a USB-BT adapter.

The range of the Bluetooth network is up to 10m (without obstacles), so you should consider how far the PC is from the emulator. **Recommended distance up to 3m.**

To connect, power must be supplied before pairing with a PC. To do this, the emulator must be connected to the ECU with power supply.

Attention! When working via BT, the emulator must not be connected via USB, otherwise a conflict is possible!

Connection setup

After you have made sure that the emulator is turned on (Red (BT) indicators should be blink) and the emulator is in a stable range, you can proceed to configure the first connection of the emulator via Bluetooth.

Connection settings will be made using the example of Windows 7 (similarly also in Win XP, Win 8, Win 10).

1. Find the Bluetooth icon in the taskbar, click and add a new Bluetooth device.
2. Select the device found (initially it can be displayed as unknown):

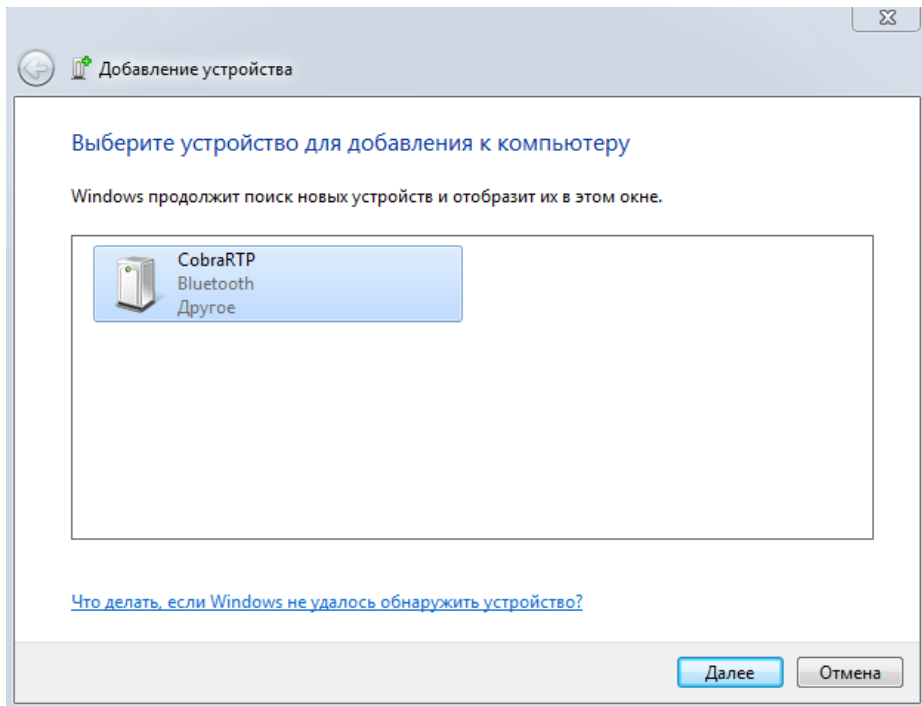

3: Select pair with password

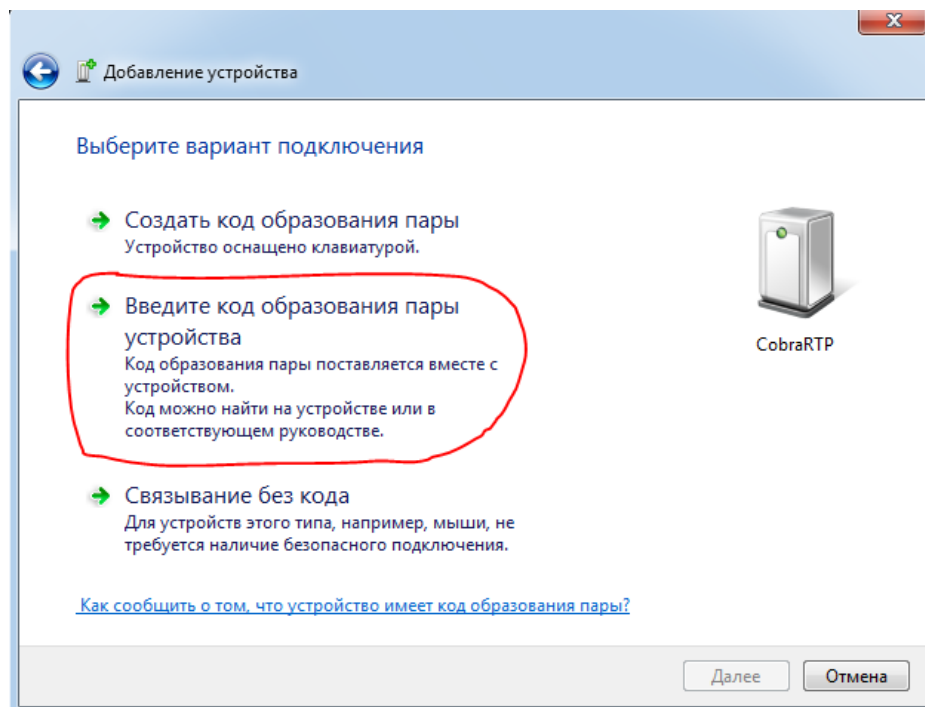

4. Enter password - **1234**:

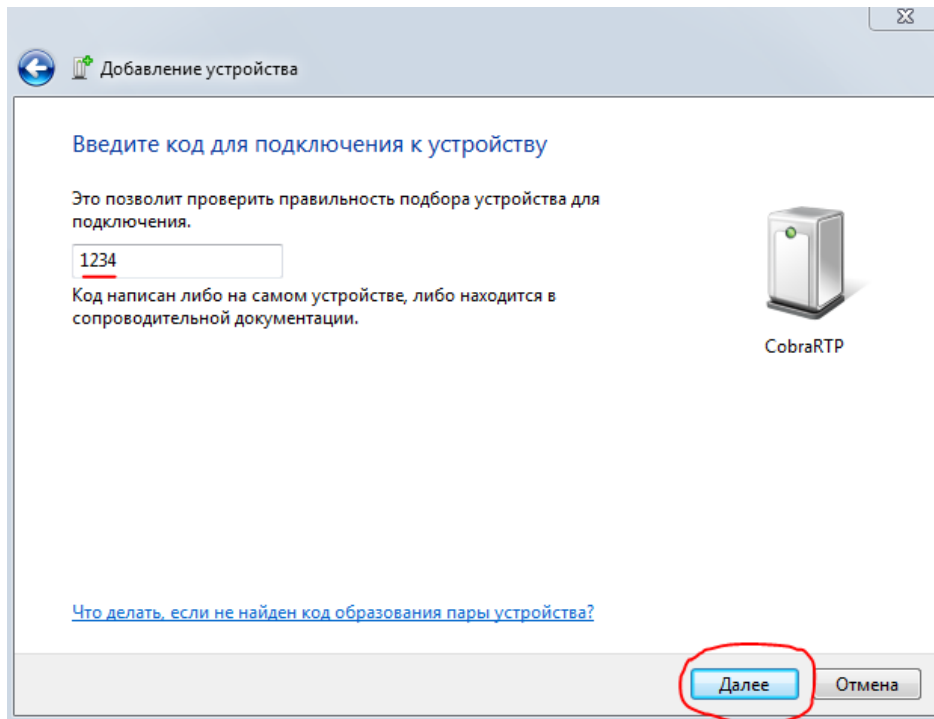

5. Successfully complete the connection setup:

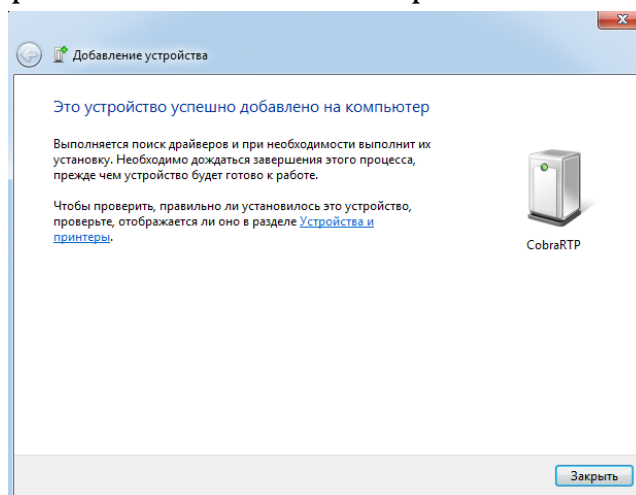

After that, **2 COM ports** should appear in the device manager.

It is worth paying attention to the fact that the system defines 2 virtual COM ports. To work with the emulator, only the “Outgoing” COM port number is always necessary. **In TunerPRO and CobraRTP Utility, the required COM port is automatically selected.**

Note:

- 1. Before connecting the device in the software, make sure that the device and the PC are ready to connect, i.e. power is supplied to the device (ignition is on) and it is in range.**
- 2. After each power loss (ignition off) for the BT version, it is necessary to reconnect in the program (it is not necessary to turn off and on the bluetooth in the PC). For TunerPRO RT, just press the connect button again:**

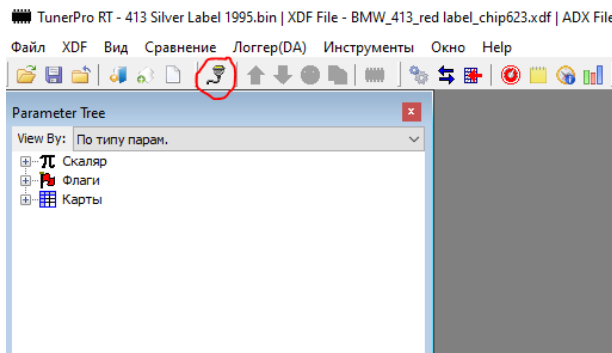

CONNECTION CHECKING

To test the functionality of all MotronicRT connection variants, you can use the **CobraRTP Utility**.

You can download the latest version on our website in the "[Downloads](#)" section.

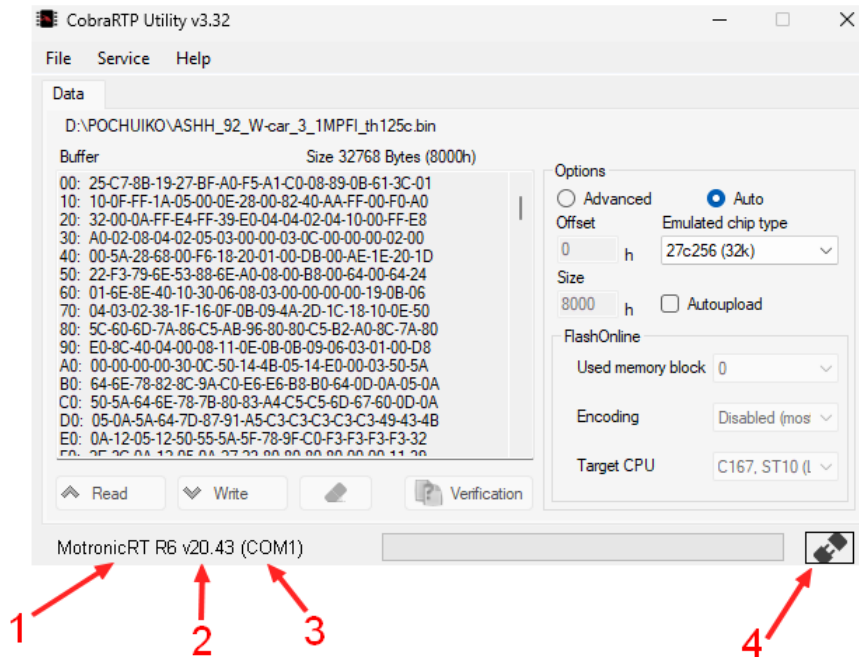

1. Device type and revision.
2. Device firmware version.
3. Number of the used COM port.
4. Connection button.

Attention! If the emulator is not recognized in TunerPRO RT, CobraRTP Utility or other software, check if the emulator is currently connected in another program! The emulator port can only be connected in one program at a time, so before connecting, make sure that the device is not connected in another program (process).

LED INDICATORS

The MotronicRT board has LED indicators for the current state of the emulator:



Status (BLUE, Yellow or Green) – emulator status indicator.

Mode-1:

At the first power-up, the indicator lights up and stays on continuously during operation.

Mode-2:

When the emulator is connected to the software, the indicator goes out and lights up again only during read, write, verification, tracing (Address hit tracing) operations.

Bluetooth (RED) – Bluetooth module status indicator (not available in USB option).

Modes:

1. Inactive (no connection). In this mode, the indicator flashes constantly, with a frequency of ~ 5 times / sec.
2. Active (connection established). In this mode, the indicator lights up ~ 1 time / 2 sec.

WORKING WITH ANALOG IN (OPTIONAL)

There are 3 universal analog inputs on the MotronicRT board that are designed to input analog signals (voltage) into the software, currently TunerPRO RT and CobraRTP utility.

Signals can be connected from three independent sources, for example: throttle position sensor (TPS); from the analog output of the controller of a broadband oxygen sensor (AFR); mass air flow sensor (MAF) and from other sources of analog signals with an output voltage in the range **0-5V**.

Input Assignment



1. **GND** – common conductor (-). Designed to connect the common point of all connected sources. It may not be necessary if the sources are vehicle sensors, but it is recommended to use it for better communication and noise immunity.
2. **1-2-3** – inputs for connecting analog signals (channels 1, 2, 3). These are directly the analog inputs to which the signal conductor of the source is connected.

Checking Analog Inputs

To check the analog inputs, you can use a battery (battery) with a nominal voltage of 1.5 - 3.7 V.

The source should be connected as shown below:

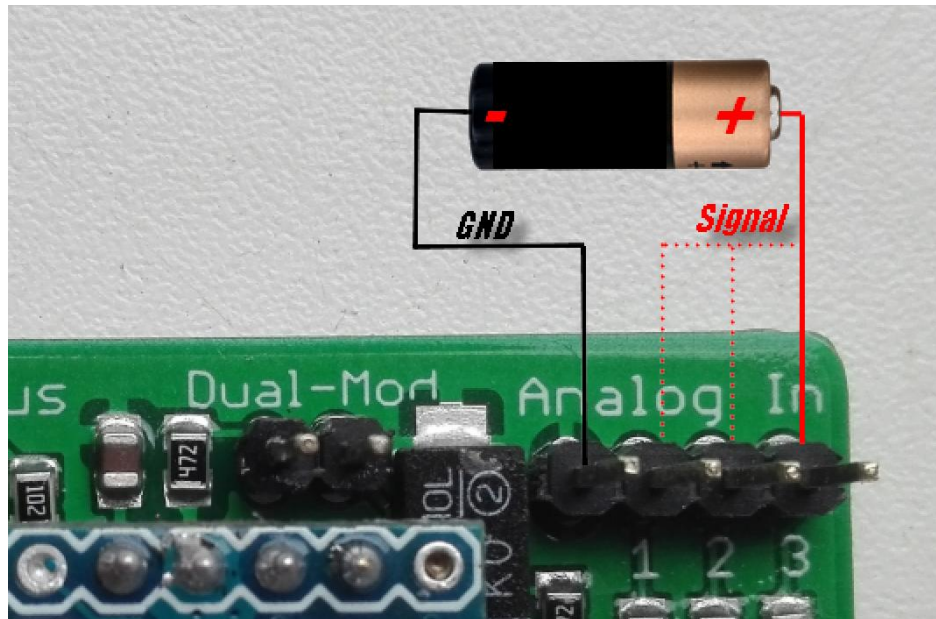

The signal conductor (in this case +) can also be connected simultaneously to all 3 channels.

Further, to display signals (voltage), you can use the CobraRTP Utility. To do this, open the utility, connect to MotronicRT (see the manual), go to the “Service” -> Analog in -> Start:

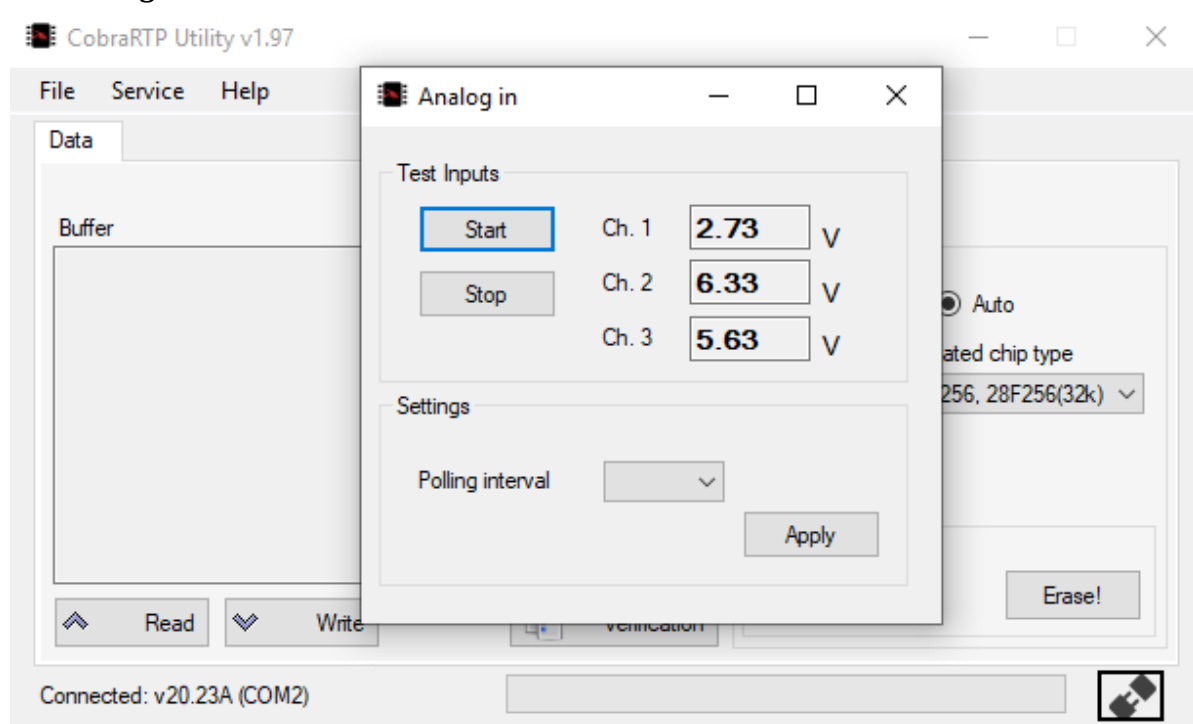

After that, the current voltage of each channel in real time should be displayed in the output windows of the corresponding channel.

Here you can change the sampling (polling) interval of analog inputs, which affects the speed of signal processing, which can correspond to 70, 130, 300 ms.

An example of connecting sensors:

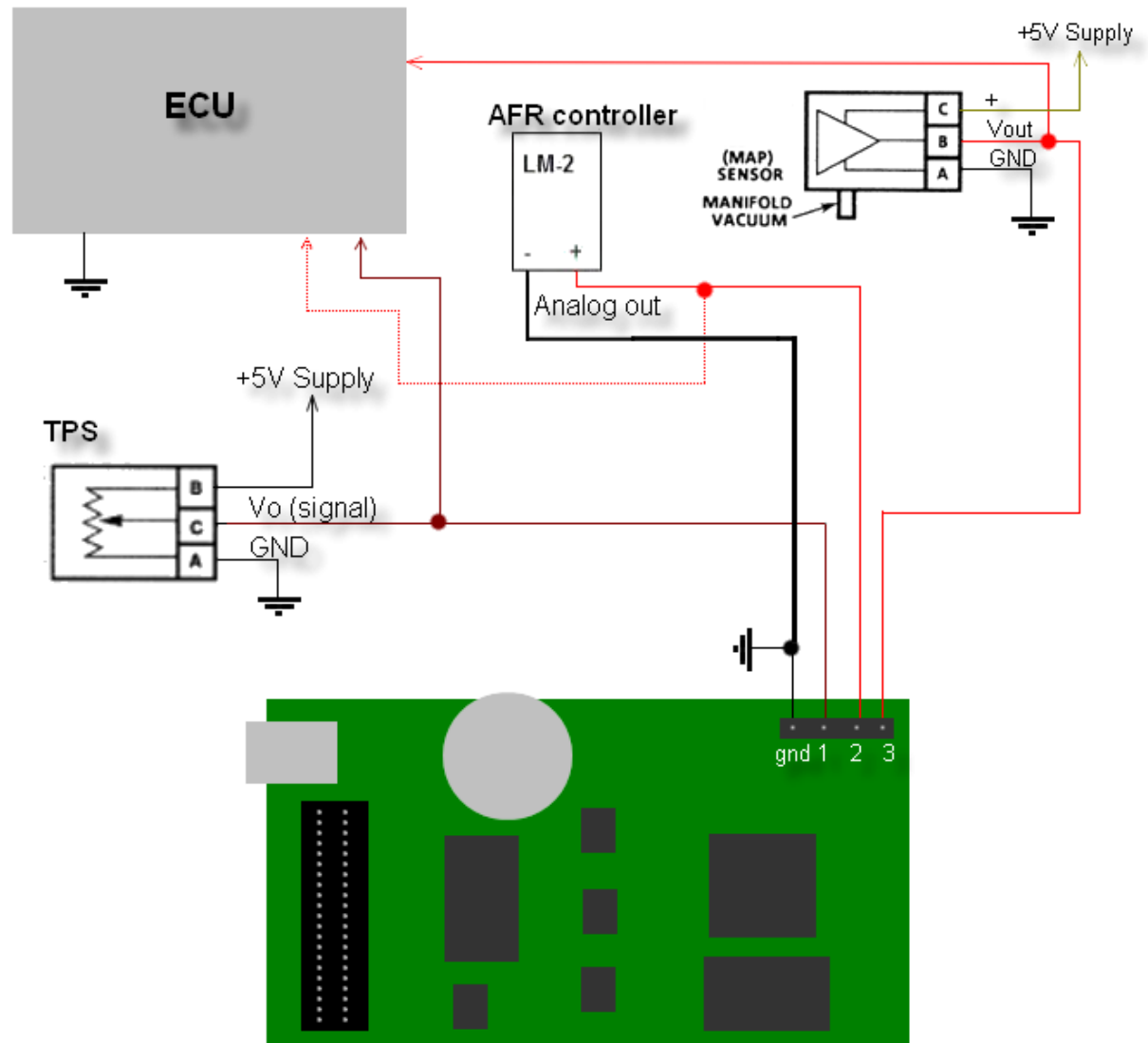

Note:

1. Dashed lines are optional.
2. All names of conductors (terminals) may differ from real ones.
3. Analog inputs do not support pulse signals (speed sensor, RPM sensor, etc.)
4. This function (data Acquisition from analog inputs) is not related to tracing!

SOFTWARE SETUP

Before running the emulator in TunerPRO, Nistune or other, you must make sure that the current *target software ID* corresponds to the program you intend to use (see CobraRTP Utility):

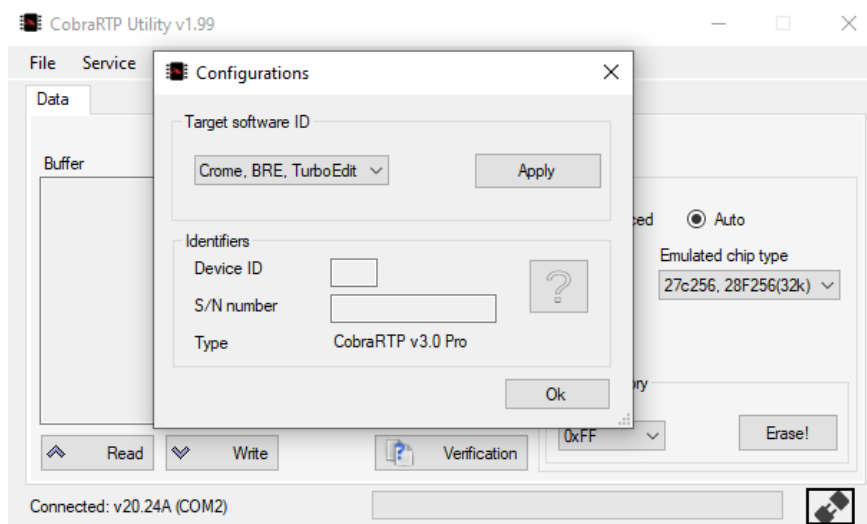

To change, you must select the appropriate software in the list and “Apply” (at a time).

TunerPRO RT

<https://www.tunerpro.net/downloadApp.htm>

No installation is required for connection to **TunerPRO RT**. When connecting, the program itself determines the necessary connection settings (if the device is available for connection).

After successful connection, the following message should appear in the program status:

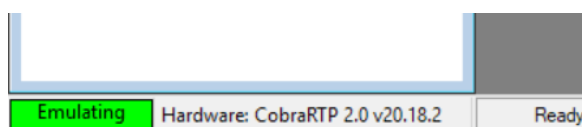

Attention! If the emulator is not recognized in TunerPRO RT, check if the emulator is currently connected in another program! The emulator port can only be connected in one program at a time, so before connecting, make sure that the device is not connected in another program. Also make sure you have the latest version of TunerPRO RT!

After this, the emulation mode is configured and you can perform tuning online. To enable online mode, use the button:

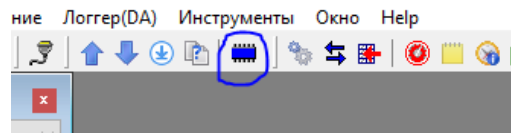

After that, to download changes to maps (tables), there is no need to **download the entire bin**, for this you can use the following button:

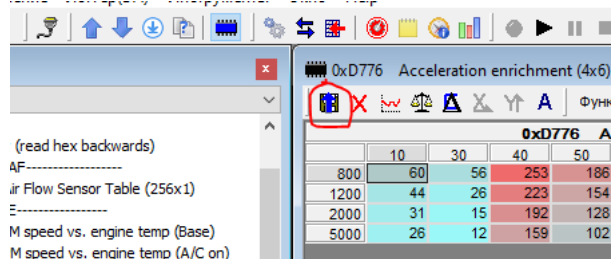

Address hit tracing

Data tracing in TunerPRO RT will allow you to track what data in tables (memory cells) the ECU processor is accessing. This is achieved without the use of additional equipment, for this it is enough to open the table (map) of interest and enable tracing:

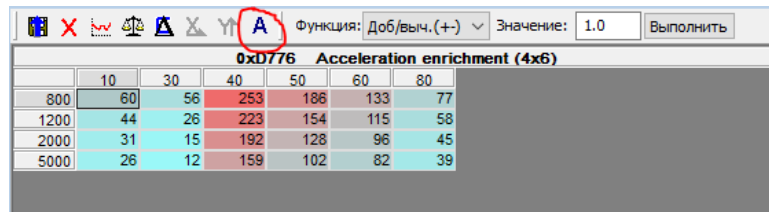

After that, a yellow cell appears on the map, which indicates which data cell on the map is currently being accessed by the CPU of the ECU.

Notes:

- You may not see the pointer (**yellow cell**) in selected table at the expected time. This does not mean that this function is not working correctly, it means that the ECU processor does not access this table (address range) at expected time. It is also possible that table is not used at all during normal engine operation, such as cranking cards, VANOS, WOT ant etc.

-For Bluetooth version, after turning off the ignition switch, you need to reconnect to the device in the software and re-connect the trace.

CONFIGURING AND ESTABLISHING A DATA ACQUISITION SYSTEM CONNECTION WITH A DEVICE (OPTIONAL, ONLY FOR ANALOG IN READING!)

1. You must install the port of the data acquisition system (DA)

This port must match the emulator port, for this you need to go: *Tools -> Preferences:*

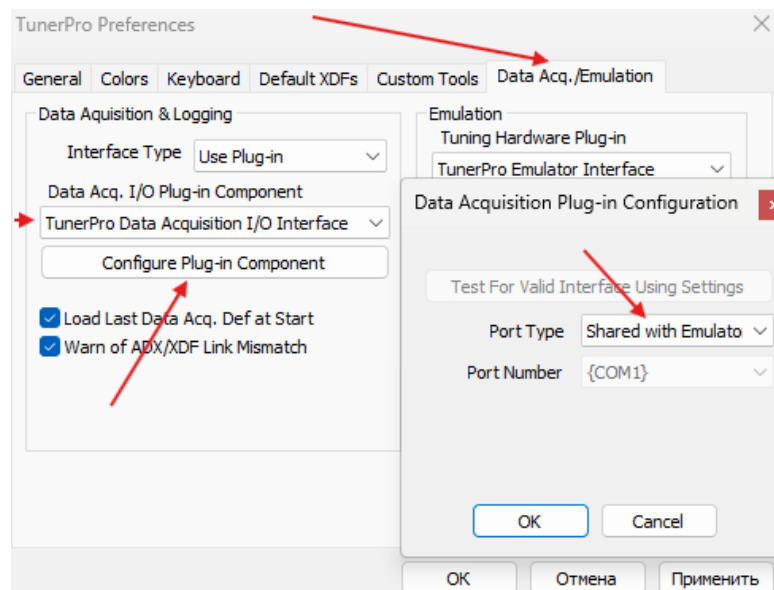

2. Select definition file (ADX)

At this step, you must open the definition file that we provide specifically for CobraRTP devices (<https://cobartrp.com/en/downloads>).

To do this, go to: *Acquisition -> Load definition file.*

After successfully downloading the definition file, the DA system is ready to connect and directly to write parameters from the device inputs.

3. Turning on the logger (DA)

To enable / disable the logger, use the button on the toolbar:



If the connection is successful, the data *acquisition* process will begin:

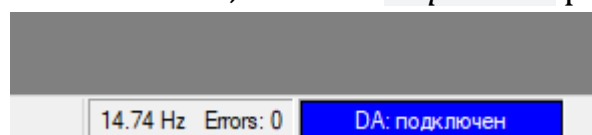

These tools are used to display virtual instruments (Data dash), graphs (Data monitors), a list (Data list), and also to record/play logs:

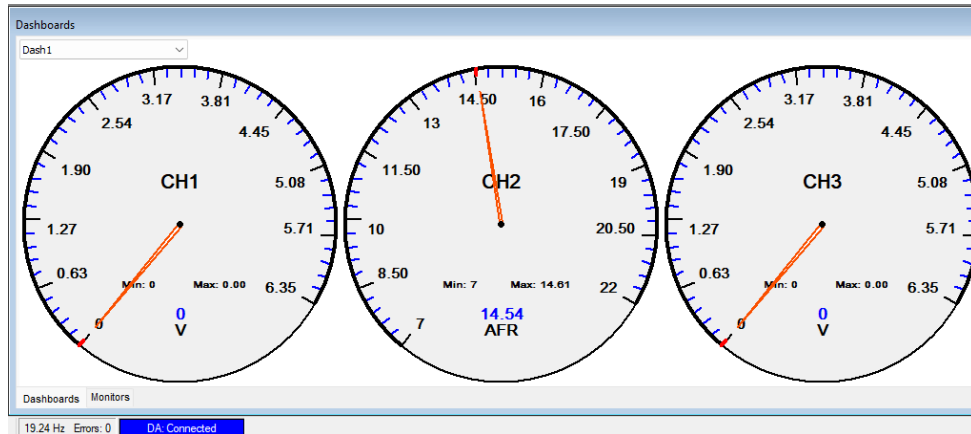

Editing a Definition File (ADX)

The definition file is a description of the data exchange protocol between the device and TunerPRO, connection settings, a list and value of parameters, a dependency that determines the conversion of received data into a convenient form and units, and other settings for processing and collecting the data stream.

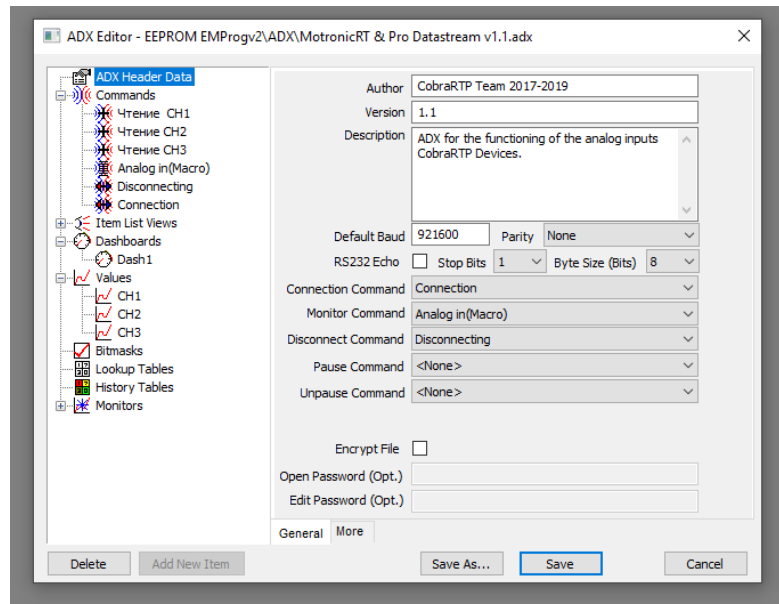

To open the editor, press the button:

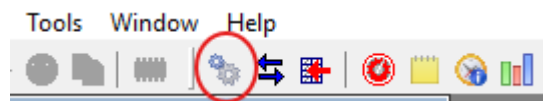

Defining the dependence of output on input voltage

To convert the data stream from the device (in this case, from the analog inputs) in the ADX file, it is possible to set the dependence of the output data on the input in the form of a mathematical formula.

Data from the device is a stream of bytes (code), the value of which varies from 0 to 255, depending on the input voltage.

The dependence of the code on the value of the input voltage on the "Analog in" is linear:

Voltage (V)	Output value(X)
0	0
5.0	201
6.35	255

To change the dependence (formula), you must go to: Value. -> select the corresponding analog channel (CHx) -> Conversion -> Set:

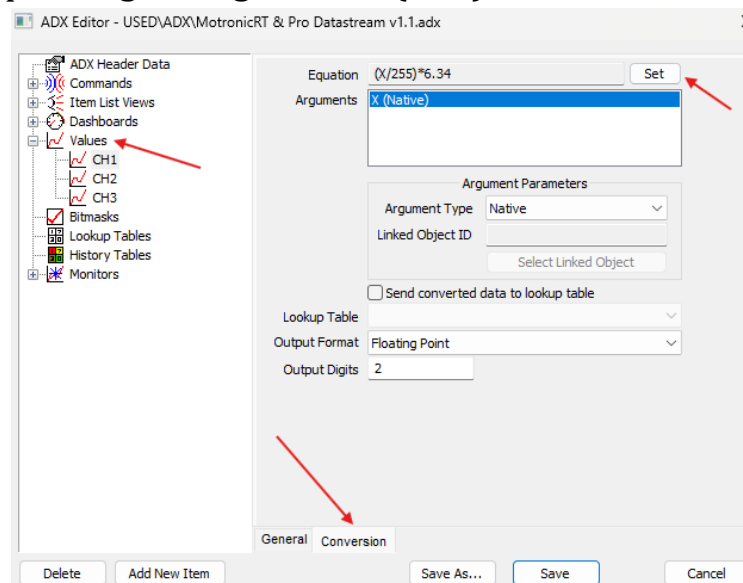

The input argument is the variable "X", which changes from 0 to 255, respectively, depending on the voltage value at Analog in according to the table above. Thus, by setting a mathematical formula, you can change the dependence of the output data on the input data. In this case, the default conversion formula is voltage (V), but you can set your own dependence, for example, to display the mixture composition. Example: at 0V = 7AFR, 5V = 22AFR, then the formula will look like: $((Y5V - Y0V)/201) * X + Y0V$, we substitute:

$((22 - 7)/201) * X + 7$. This formula is universal and can be applied to many sensors, such as MAP, TPS, etc.

Change displayed units

Also, for convenience, you can set any units displayed on virtual devices. Also here you can set the boundaries of the range of displayed values. To do this, go to:

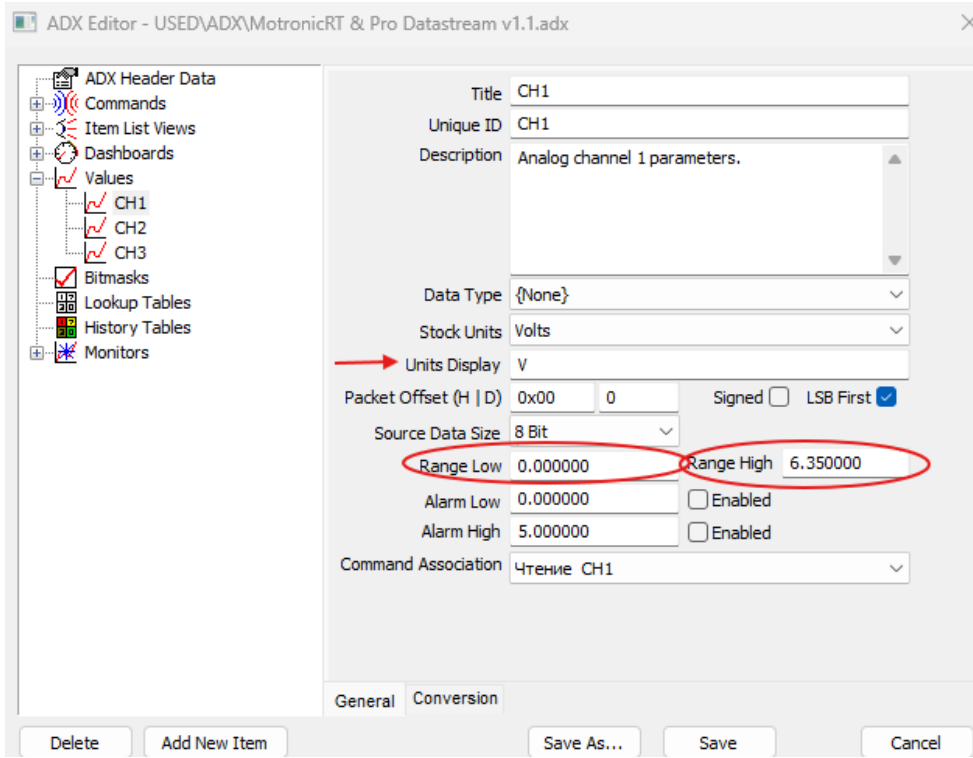

You can find details of other parameters in the program's help (*Help menu*).

Notes:

1. When uploading firmware (full) to Emulator, it is advisable to disable tracing.
2. The collaboration of logging (DA) and online mode may not be compatible, especially with large amounts of data.
3. To work with the firmware, it is recommended to use the online mode, i.e. partial change of tables (firmware). No need to upload all firmware after changing tables (parameters).

Nistune

(<https://www.nistune.com/support/software-downloads>)

To use the emulator with Nistune, you need to set the following settings:

Nissan Consult Options:

Consult Type: Auto
 Consult Interface Compatible
 Auto connect on startup
 Retry connect on error
 Bluetooth friendly port scan
Port scan timeout: 40 Rescan ports

Wideband Type
None Port: COM13: (used) CobraRTP
None Port: COM13: (used) CobraRTP

Searching for
Moates Ostrich Port: Auto
Emulator offset: 8000

Miscellaneous Settings
 Auto Reset Max Window: 5 User mode: Expert
 Map highlighting
 Debug Logging
 Enable sounds
 Verify loaded image
 Invert RPM scale

Notes:

1. The value of Emulator offset for firmware (bin) 32kB (most ECUs with ROM type 27s256) - 8000;
for 16kB - 4000;
for 64kB - 0000.
2. To emulate 16 bit (2 chips) ECUs, you need 2 CobraRTP emulators and an expansion board ([дочерняя](#)).

More info:

http://nistune.com/docs/NISTune_Emulator_Tutorial.pdf

http://nistune.com/docs/NISTune_Type_2_Hardware_Install_Sheet.pdf

DUAL-MODE (DUALMAP)

MotronicRT allows you to download and use two different firmware (Bin). To do this, a “Dual-mod” jumper is provided on the MotronicRT board, with which the firmware (memory bank) is selected:

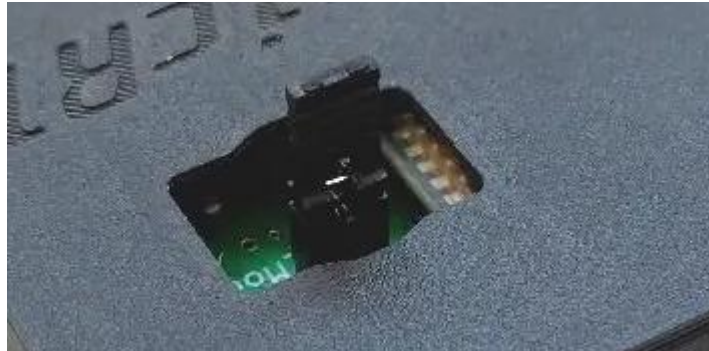

Upload ROMs

Upload firmware in the following order:

1. Upload ROM 1 (jumper installed - contact closed)
2. Upload ROM 2 (jumper removed - contact open)

Thus, closing and opening the contact of the “Dual-Mod” jumper, we select a memory bank and load different firmware into different areas of the emulator’s memory.

Usage

To use, you can select the desired memory bank, i.e. firmware using the status of the jumper (closed / open), in accordance with the order of the loaded firmware.

For convenience, you can use the toggle switch, brought out at a short distance (recommended no more than 1m) using a 2-core cable.

Switching ROMs is allowed to be done with the engine running.

Also you can see video manual: <https://youtu.be/CiyAftnVTDO>

TROUBLESHOOTING

The engine does not start, the ECU does not go to diagnostics

1. Check if the firmware is compatible with your ECU
2. check if the checksum is correct
3. Wrong type of emulated memory selected when uploading firmware via CobraRTP Utility
4. check all contacts and connections of the device with the computer.

TunerPRO RT does not recognize the device

1. Make sure that the emulator port is not busy by another program, such as CobraRTP Utility
2. Check if the drivers are installed if driver installation is required (see the Connecting to a PC section). You can check if the drivers are installed correctly in the Device Manager.
3. Make sure that you are using the latest TunerPRO RT build version instead of TunerPRO.

Tracing does not work in TunerPRO RT

1. You may have selected an inactive map (see Address hit tracing)
2. Check if the firmware parameters are correct in the XDF - Bin size (HEX) settings. This value should be equal to the actual size of the firmware file, for example, if the firmware is 32kB, then this value should be 8000 in hexadecimal system (HEX), and Address offset 0.
3. Make sure the XDF file matches your firmware (bin).
4. Make sure your emulator firmware is up to date.

An error occurs when loading data into the emulator

1. If an error occurs during the download - Replace the USB cable.
2. If the error appears only in TunerPRO RT, and in CobraRTP Utility the data exchange with the emulator is in order, check if the firmware parameters are specified correctly in the XDF - Bin size (HEX) settings. This value should be equal to the actual size of the firmware file, for example, if the firmware is 32kB, then this value should be 8000 in hexadecimal system (HEX), and Address offset 0.
3. If you use Bluetooth pairing, do not forget to connect again in the program after turning off the emulator (ignition).

GENERAL NOTES

1. Always be careful when installing (connecting) the device to the computer, improper connection can lead to damage to the device.
2. Always use a high-quality and as short as possible USB cable for reliable system operation.
3. Avoid installing the board in a place with metal objects that could lead to short circuits or voltage supply to unprotected areas of the device. Otherwise, isolate the device reliably from the environment.

SPECIFICATIONS

Electrical:

1. Supply voltage5 V ($\pm 10\%$)
2. Supply current.....150 mA
3. Memory access time, no more.....90 nS
4. Input voltage range of analog inputs0-6.34 V
5. Ambient temperature -20...+50°C

CobraRTP Team ©2018.

Support: <https://cobarotp.com/en/feedback>